

ROLL CUTTING RAIL TYPE 740
(A570)

PARTS CATALOG

INTRODUCTION

This chapter instructs you the numbers and names of parts on this machine.

INDEX to PARTS CATALOG

1.CUTTER UNIT (A570)	2
PARTS INDEX	5

1. CUTTER UNIT (A570)

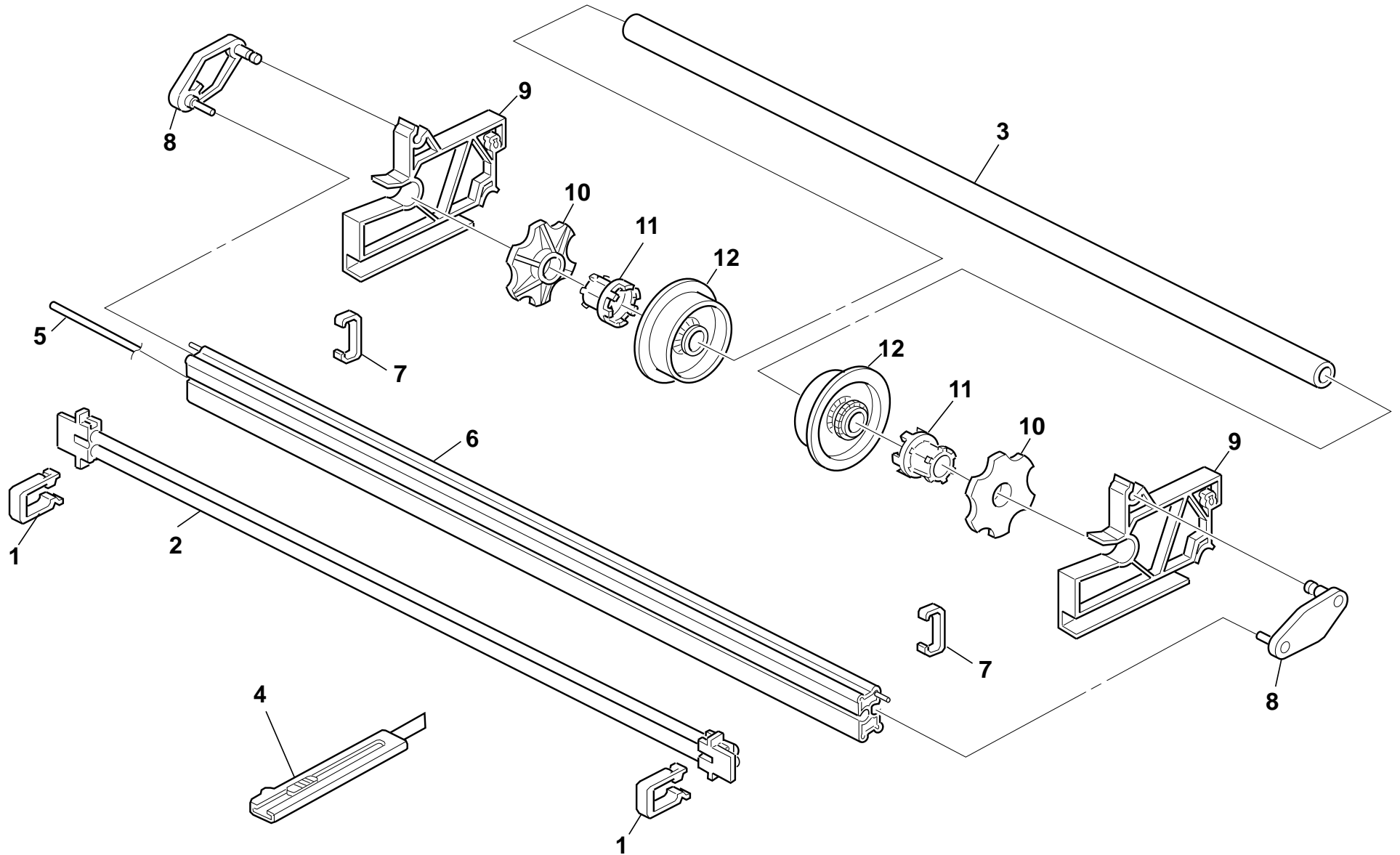

1. CUTTER UNIT (A570)

Index No.	Part No.	Description	Q'ty Per Assembly
1	A570 6654	Fixing Holder	2
2	A570 6658	Slide Shaft	1
3	A570 6553	Roll Paper Shaft	1
4	A570 6563	Cutter Knife	1
5	A570 6587	Guide Shaft	1
6	A570 6580	Cutter Stay	1
7	A570 6656	Holder Hook	1
8	A570 6569	Roll Paper Arm	2
9	A570 6551	Roll Shaft Holder	2
10	A570 6560	Lock Click	2
11	A570 6561	Roll Paper Sleeve	2
12	A570 6559	Roll Flange	2

Index No.	Part No.	Description	Q'ty Per Assembly
-----------	----------	-------------	-------------------

PARTS INDEX

Part No.	Description	Page and Index No.
A570 6551	Roll Shaft Holder	3- 9
A570 6553	Roll Paper Shaft	3- 3
A570 6559	Roll Flange	3- 12
A570 6560	Lock Click	3- 10
A570 6561	Roll Paper Sleeve	3- 11
A570 6563	Cutter Knife	3- 4
A570 6569	Roll Paper Arm	3- 8
A570 6580	Cutter Stay	3- 6
A570 6587	Guide Shaft	3- 5
A570 6654	Fixing Holder	3- 1
A570 6656	Holder Hook	3- 7
A570 6658	Slide Shaft	3- 2

Part No.	Description	Page and Index No